

LED Lighting Solutions

The future of illumination



LED-8-A0601

Energy Efficient Indoor Commercial Lighting.

FEATURES

- Fixture is made of heavy duty steel
- Optimized and highly penetrating transparent film
- Electrostatic painting enhances environment resistance and aging process.
- High efficient LED allows for maximum light output while reducing energy consumption.
- Environmentally friendly
- Long lifespan

APPLICATIONS

- Offices
- Exhibition Halls
- Grocery Stores
- Warehouses
- Industrial Plants

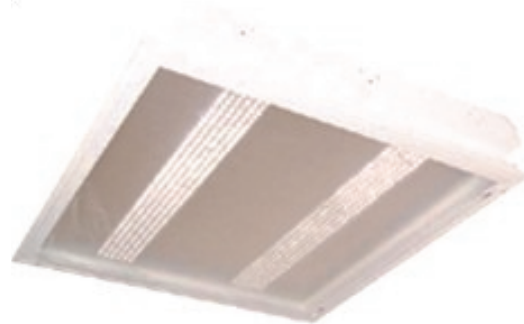

- **Voltage Input:**
Standard = 90-260 VAC 50/60 HZ
Optional = 24 VDC
- **Color Temperature:**
Standard = 5000-6000K
Other colors available up to 6500K
- **Power consumption:**
32W, 40W, 50W
- **Beam Angle: 130°**

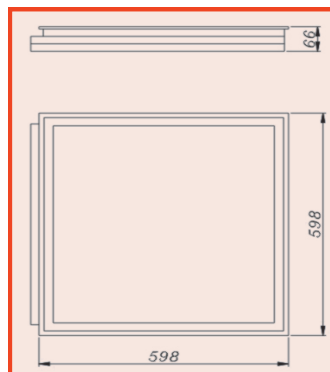
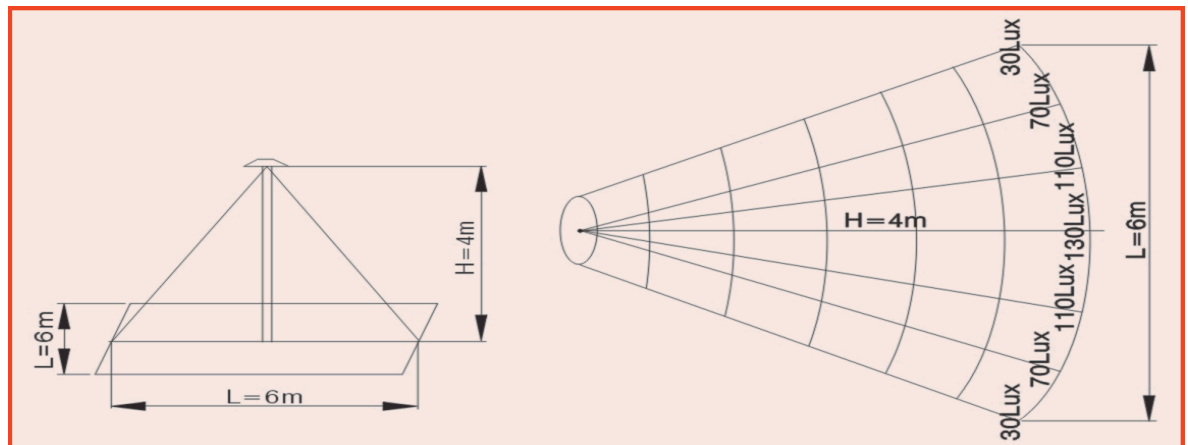

Examples:

| P/N | Power (W) | Luminous flux (lm) | Color (K) | Lux / Distance (H/ m) | Scope L (m) |
|------------------|----------------|-----------------------|----------------|--------------------------|----------------|
| LED-8-A0601 | 32 | 1800 | 5000 - 6000 | 130/4 | 6 |
| LED-8-A0601A | 40 | 2200 | 5000 - 6000 | 180/4 | 6 |
| NEW LED-8-A0601B | 50 | 2600 | 5000 - 6000 | TBD | TBD |

Class 1, IEC598, IP60, CE. Specifications and dimension subject to change. Please contact us for latest information.

Ledimation, Inc.

2035 Royal Lane, Suite 200

Dallas, Texas 75229

Phone 972.955.9990

Fax 214.241.0916

www.ledimation.com

